

Range summary/Technical comparison

Flap fitting system Lift Advanced

	Lift Advanced HF	Lift Advanced HK
Page number	4 - 7	8 - 11
		
Flap movement	Folding-flap fitting	Flap fitting
Flap weight	max. 15,2 kg	max. 20,7 kg
Opening/closing force adjustable	✓	✓
Silent System integrated	Dampened closing action	Dampened closing action
Door/door-frame material	Timber/timber, aluminium	Timber/timber, aluminium
Inside cabinet dimensions		
Height	440 - 925 mm	min. 276 - 720 mm
Depth	min. 182 mm	min. 182 mm
Width	min. 300 mm	min. 300 mm
Front panel adjustment		
Height	± 2 mm	± 2 mm
Side	± 2 mm	± 2 mm
Depth	± 2 mm	± 2 mm
Material of housing/hinge mechanism	Grey plastic/aluminium silver	Grey plastic/aluminium silver

Lift Advanced HL	Lift Advanced HS
12 - 15	16 - 19
	
Flap lift fitting	Lift-up flap fitting
max. 18,5 kg	max. 15,9 kg
✓	✓
Dampened closing action	Dampened closing action
Timber/timber, aluminium	Timber/timber, aluminium
277 - 462 mm	380 - 750 mm
min. 182 mm	min. 182 mm
min. 300 mm	min. 300 mm
± 2 mm	± 2 mm
± 2 mm	± 2 mm
± 2 mm	± 2 mm
Grey plastic/aluminium silver	Grey plastic/aluminium silver



- For timber fronts and timber or aluminium framed fronts
- Max. flap/door weight 15,2 kg
- Adjustable opening and closing force
- Centre hinge not required
- Cross member not required
- Different front heights possible for cabinet heights of 550 mm or more
- Silent System integrated – dampened closing action
- The fitting can be adapted to different front weights by means of gas pressure springs which must be ordered separately, see pages 5 - 6
- Identical cabinet drilling pattern for Lift Advanced HF/HK/HL/HS
- Including fixing accessories
- Three-dimensional front adjustment :
Height ± 2 mm, side ± 2 mm, depth ± 2 mm
- Inside cabinet dimensions:
Height 440 - 925 mm
Depth min. 182 mm
Width min. 300 mm
- Housing and hinge mechanism of grey plastic/silver aluminium

Set contains:

- 1 flap fitting right/left
- 2 front adapters
- Fixing accessories

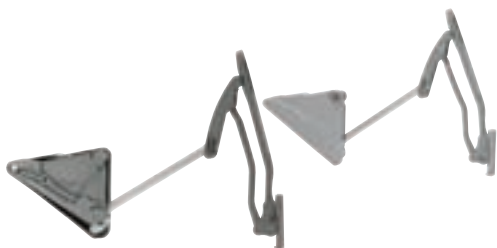

Internal cabinet height mm	Order no.	PU
440 - 550	9 079 605	1 set
550 - 610	9 079 607	1 set
610 - 700	9 079 610	1 set
700 - 770	9 079 614	1 set
770 - 925	9 079 615	1 set

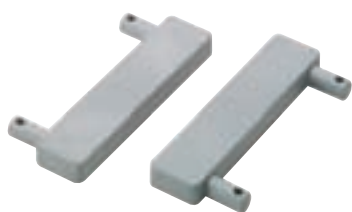

Adapter for aluminium frame profile

- For connecting the lift-and-fold fitting Lift Advanced HF to aluminium frame profiles with a frame width of 19 mm

Order no.	PU
9 079 601	1 set



Pneumatic action

- For adapting the lift-and-fold fitting Lift Advanced HF to different flap weights
- Simple installation and removal

Set contains:

2 springs (usable left and right)

Pneumatic action

for folding-flap fitting Lift Advanced HF (order no. 9 079 605)

Internal cabinet height 440 - 550 mm

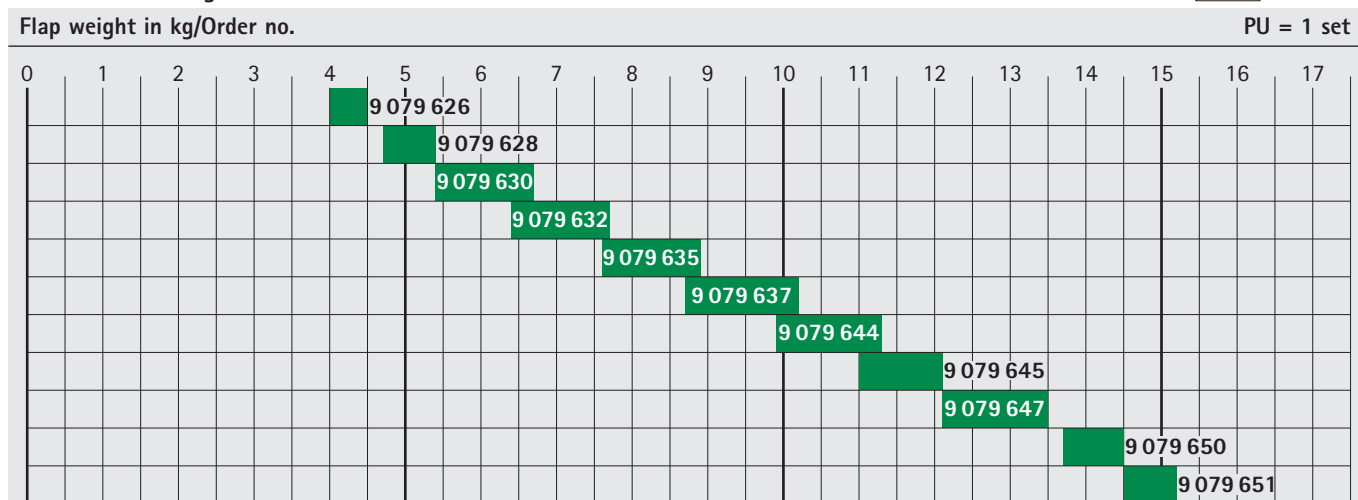
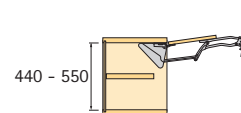

Pneumatic action

for folding-flap fitting Lift Advanced HF (order no. 9 079 607)

Internal cabinet height 550 - 610 mm

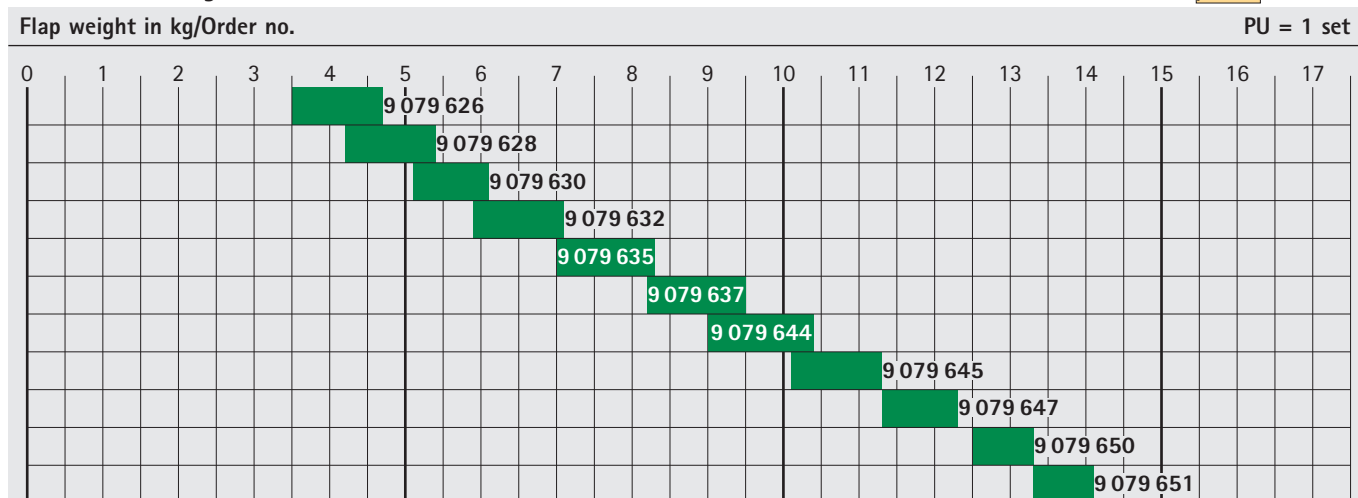
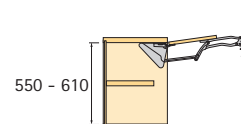

Folding-flap fitting Lift Advanced HF



Pneumatic action

for folding-flap fitting Lift Advanced HF (order no. 9 079 610)
Internal cabinet height 610 - 700 mm

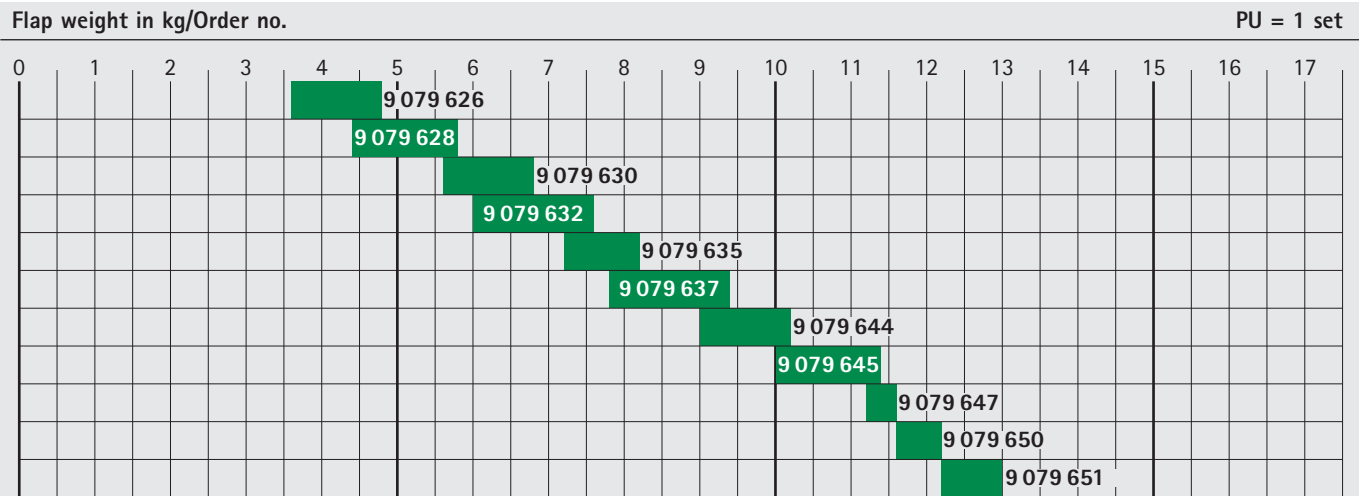
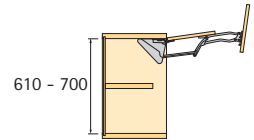

Pneumatic action

for folding-flap fitting Lift Advanced HF (order no. 9 079 614)
Internal cabinet height 700 - 770 mm

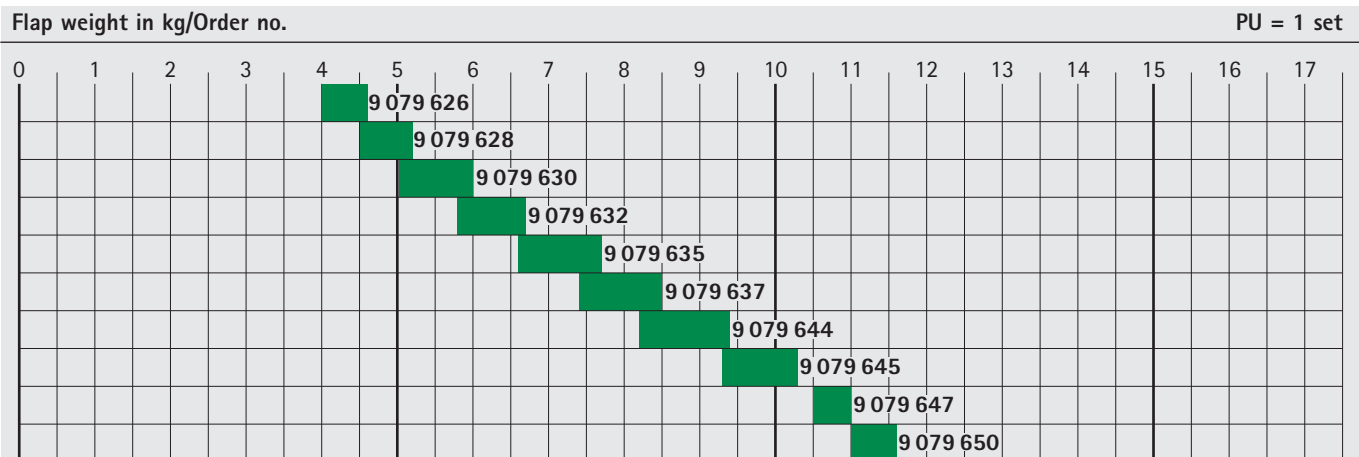
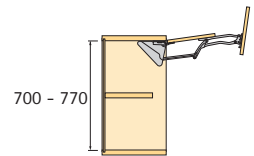

Pneumatic action

for folding-flap fitting Lift Advanced HF (order no. 9 079 615)
Internal cabinet height 770 - 925 mm

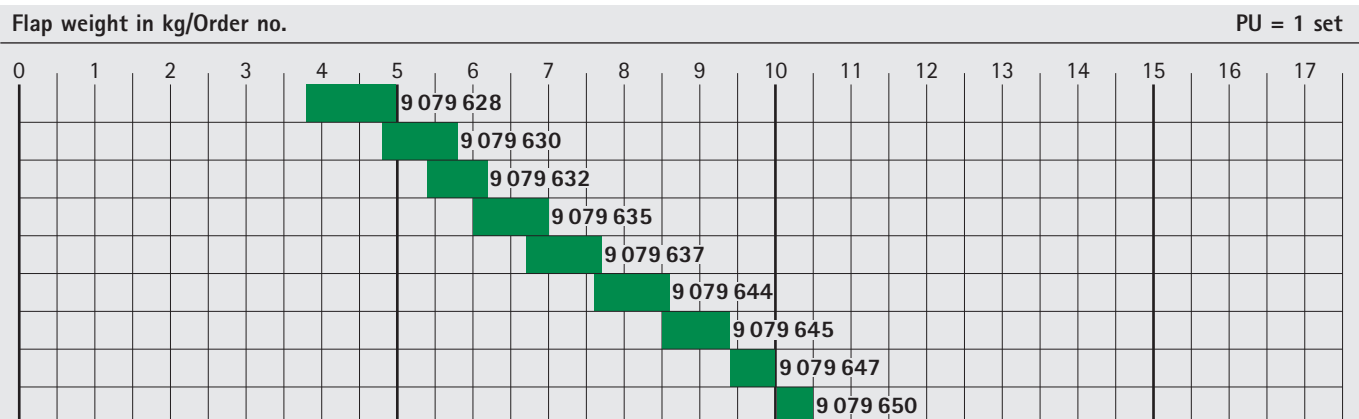
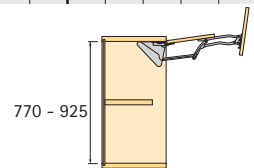

Cabinet drilling pattern

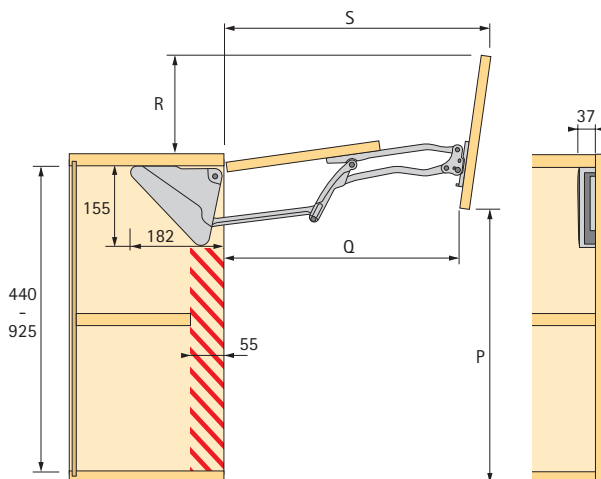
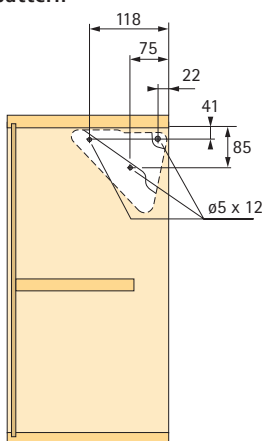

Internal cabinet height mm	Size P mm	Q mm	R mm	S mm	T mm	U mm
440 - 550	430	383	179	440	120	351
550 - 610	468	404	163	547	154	385
610 - 700	506	418	141	494	184	415
700 - 770	544	439	138	522	214	445
770 - 925	582	457	126	547	244	475

Front drilling pattern

for timber/timber-framed fronts and aluminium frame profiles 45 mm convex and 55 mm straight/convex

Front drilling pattern

for aluminium frame profile 19 mm

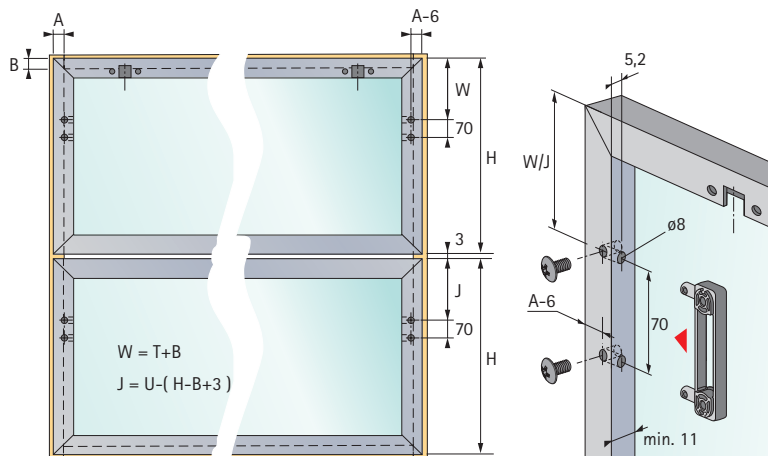
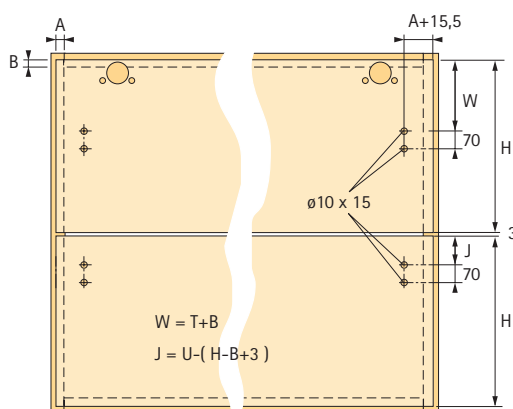

Hole pattern

for fronts of different heights

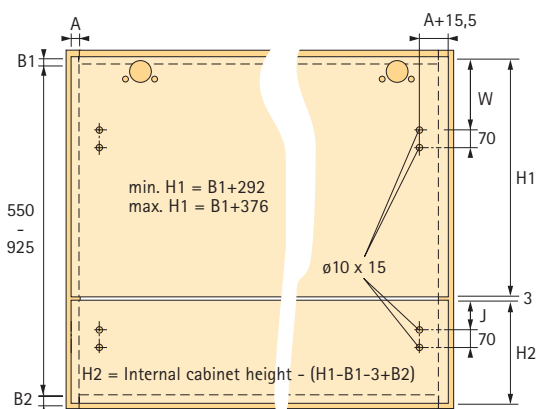



- For timber fronts and timber or aluminium framed fronts
- Max. flap/door weight 20,7 kg
- Adjustable opening and closing force
- Silent System integrated – dampened closing action
- The fitting can be adapted to different front weights by means of gas pressure springs which must be ordered separately, see pages 9 - 10
- Identical cabinet drilling pattern for Lift Advanced HF/HK/HL/HS
- Including fixing accessories
- Three-dimensional front adjustment :
Height: ± 2 mm, side ± 2 mm, depth ± 2 mm
- Inside cabinet dimensions:
Height 276 - 720 mm
Depth min. 182 mm
Width min. 300 mm
- Housing and hinge mechanism of grey plastic/silver aluminium

Set contains:

- 1 flap fitting right/left
- 2 front adapters
- Fixing accessories



Internal cabinet height mm	Order no.	PU
276 - 720	9 079 603	1 set

Adapter for aluminium frame profile

- For connecting the lift-up fitting Lift Advanced HK to aluminium frame profiles with a frame width of 19 mm



Order no.	PU
9 079 709	1 set



Pneumatic action

- For adapting the lift-up fitting Lift Advanced HK to different flap weights
- Simple installation and removal

Set contains:

2 springs (usable left and right)

Pneumatic action

for flap fitting Lift Advanced HK

Internal cabinet height 276 - 360 mm

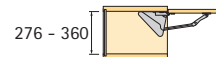

Flap weight in kg/Order no.		PU = 1 set
3	4	9 079 618
5	6	9 079 619
7	8	9 079 622
9	10	9 079 624
11	12	9 079 626
13	14	9 079 628
15	16	9 079 630
17	18	9 079 632
19	20	9 079 635
21	22	9 079 637
23	24	9 079 644

Pneumatic action

for flap fitting Lift Advanced HK

Internal cabinet height 360 - 480 mm

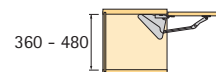

Flap weight in kg/Order no.		PU = 1 set
2	3	9 079 618
4	5	9 079 619
6	7	9 079 622
8	9	9 079 624
10	11	9 079 626
12	13	9 079 628
14	15	9 079 630
16	17	9 079 632
18	19	9 079 635
20	21	9 079 637
22	23	9 079 644

Flap fitting Lift Advanced HK



Pneumatic action

for flap fitting Lift Advanced HK

Internal cabinet height 480 - 540 mm

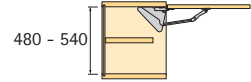

Flap weight in kg/Order no.

PU = 1 set

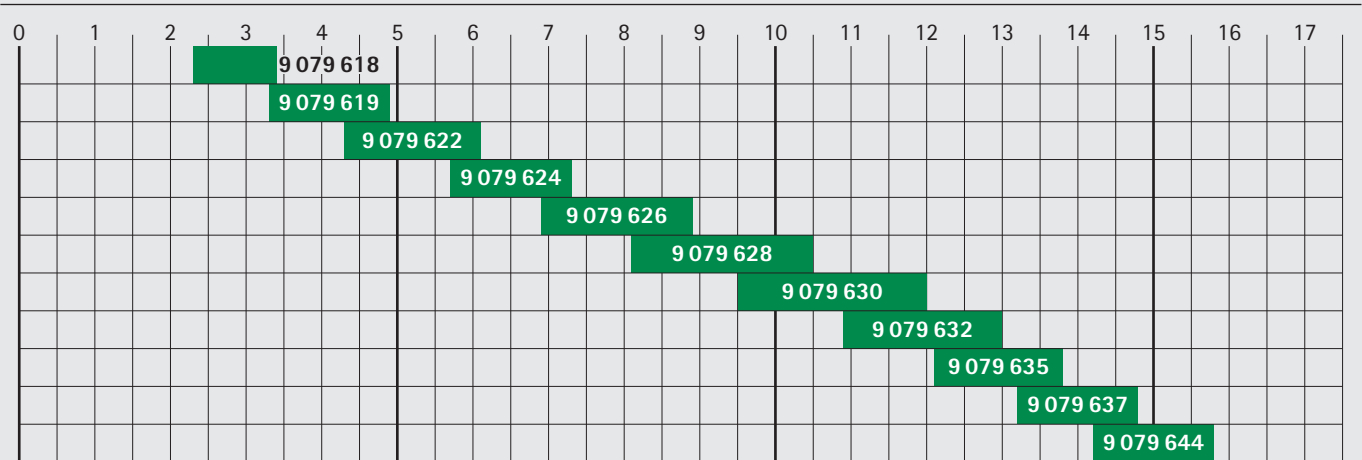

Pneumatic action

for flap fitting Lift Advanced HK

Internal cabinet height 540 - 600 mm

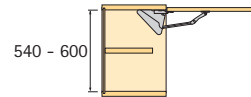

Flap weight in kg/Order no.

PU = 1 set

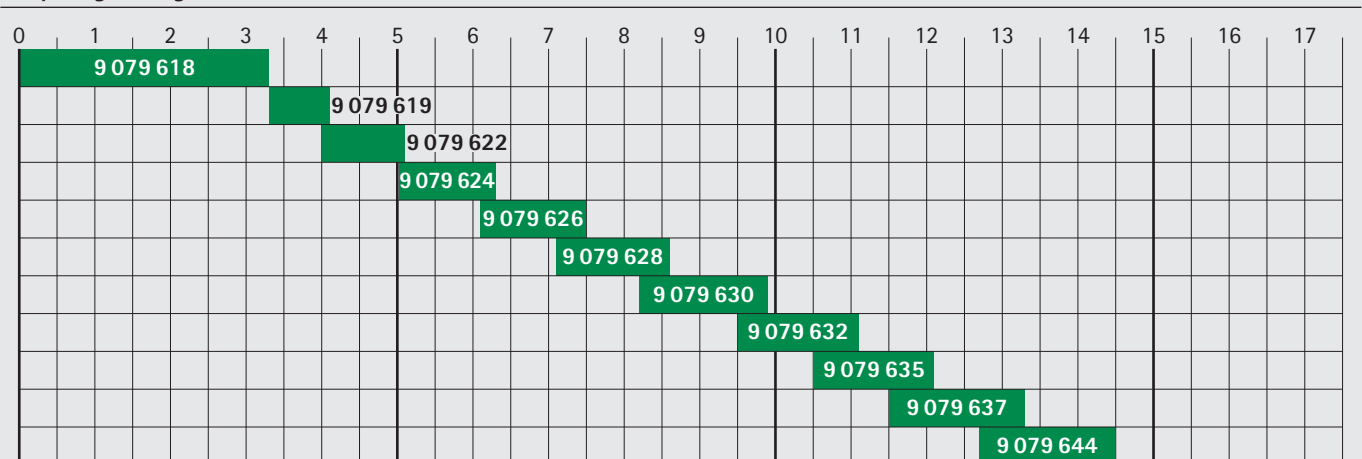

Pneumatic action

for flap fitting Lift Advanced HK

Internal cabinet height 600 - 720 mm

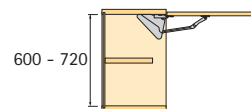

Flap weight in kg/Order no.

PU = 1 set

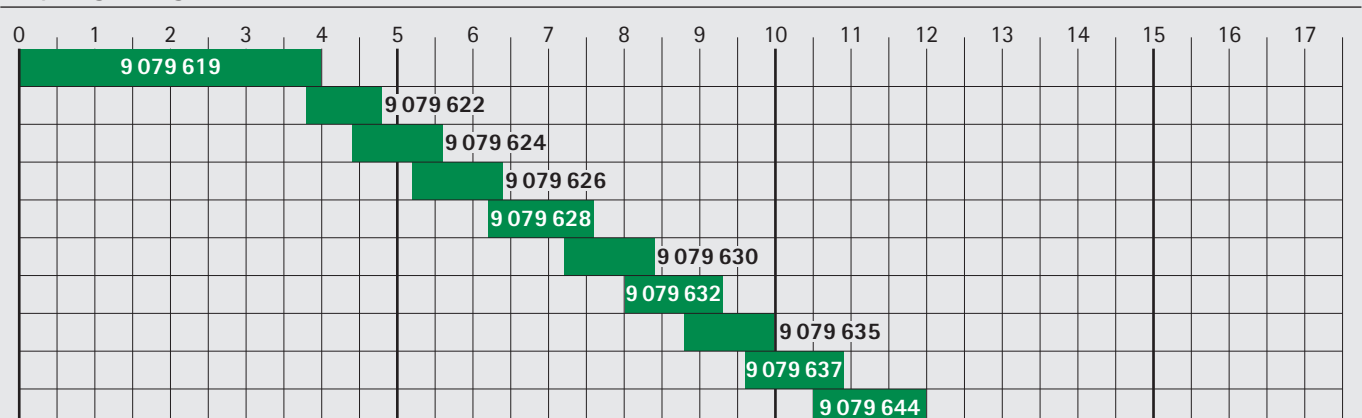

Cabinet drilling pattern

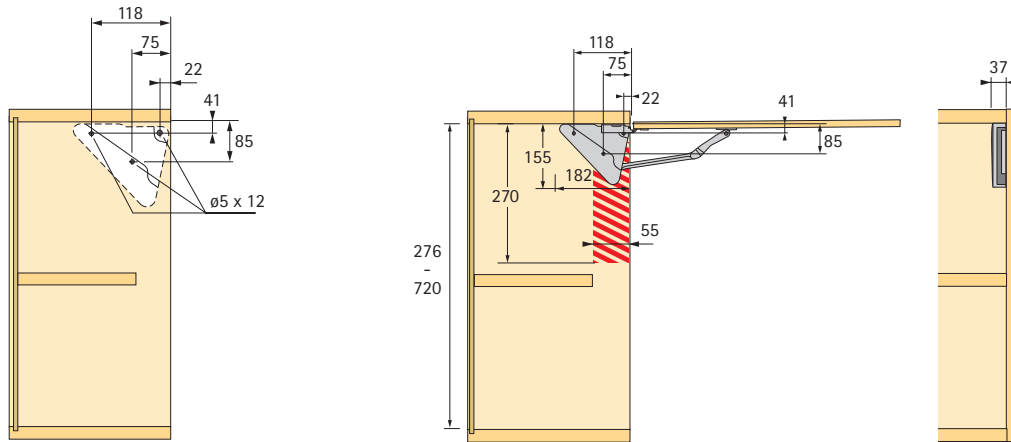

Front drilling pattern

for timber/timber-framed fronts and aluminium frame profiles 45 mm convex and 55 mm straight/convex

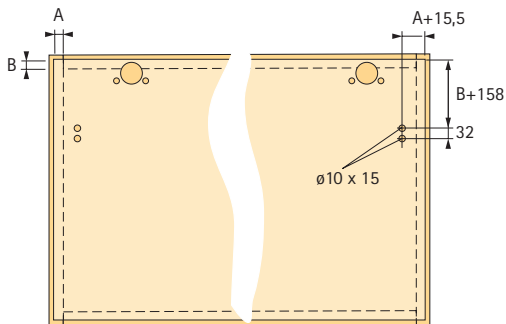

Front drilling pattern

for aluminium frame profile 19 mm

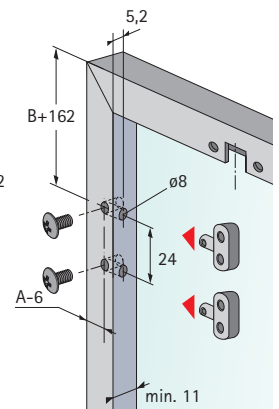
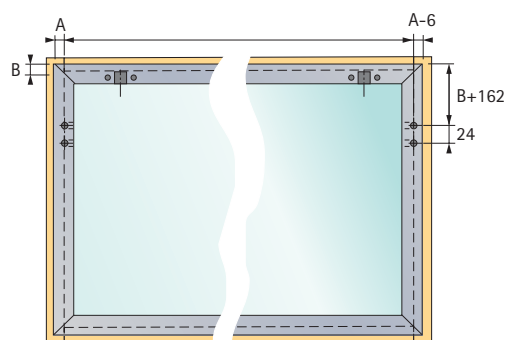



- For timber fronts and timber or aluminium framed fronts
- Max. flap/door weight 18,5 kg
- Adjustable opening and closing force
- Silent System integrated – dampened closing action
- The fitting can be adapted to different front weights by means of gas pressure springs which must be ordered separately, see pages 13 - 14
- Identical cabinet drilling pattern for Lift Advanced HF/HK/HL/HS
- Including fixing accessories
- Three-dimensional front adjustment :
Height ± 2 mm, side ± 2 mm, depth ± 2 mm
- Inside cabinet dimensions:
Height 277 - 462 mm
Depth min. 182 mm
Width min. 300 mm
- Housing and hinge mechanism of grey plastic / silver aluminium

Set contains:

- 1 flap fitting right/left
- 2 front adapters
- Fixing accessories



Internal cabinet height mm	Order no.	PU
277 - 312	9 079 595	1 set
312 - 342	9 079 597	1 set
342 - 372	9 079 598	1 set
372 - 402	9 079 599	1 set
402 - 462	9 079 600	1 set

Shortenable cross member for flap lift fitting Lift Advanced HL



For cabinet width mm	Order no.	PU
600	9 079 653	1 set
1200	9 079 658	1 set
1800	9 079 664	1 set



Adapter for aluminium frame profile

- For connecting the high-rise fitting Lift Advanced HL to aluminium frame profiles with a frame width of 19 mm

Order no.	PU
9 079 601	1 set



Pneumatic action

- For adapting the high-rise fitting Lift Advanced HL to different flap weights
- Simple installation and removal

Set contains:

2 springs (usable left and right)

Pneumatic action

for flap lift fitting Lift Advanced HL (Order no. 9 079 595)

Internal cabinet height 277 - 312 mm

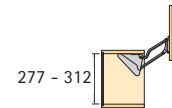

PU = 1 set

Flap weight in kg/Order no.

1	2	3	4	5	6	7	8	9	10	11	12	13	14	15	16	17	18
	9 079 618																
			9 079 619														
				9 079 622													
					9 079 624												
						9 079 626											
							9 079 628										

Pneumatic action

for flap lift fitting Lift Advanced HL (Order no. 9 079 597)

Internal cabinet height 312 - 342 mm

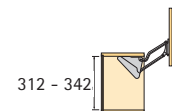

PU = 1 set

Flap weight in kg/Order no.

1	2	3	4	5	6	7	8	9	10	11	12	13	14	15	16	17	18
	9 079 618																
		9 079 619															
			9 079 622														
				9 079 624													
					9 079 626												
						9 079 628											
							9 079 630										
								9 079 632									
									9 079 635								
										9 079 637							
											9 079 644						

Cabinet drilling pattern

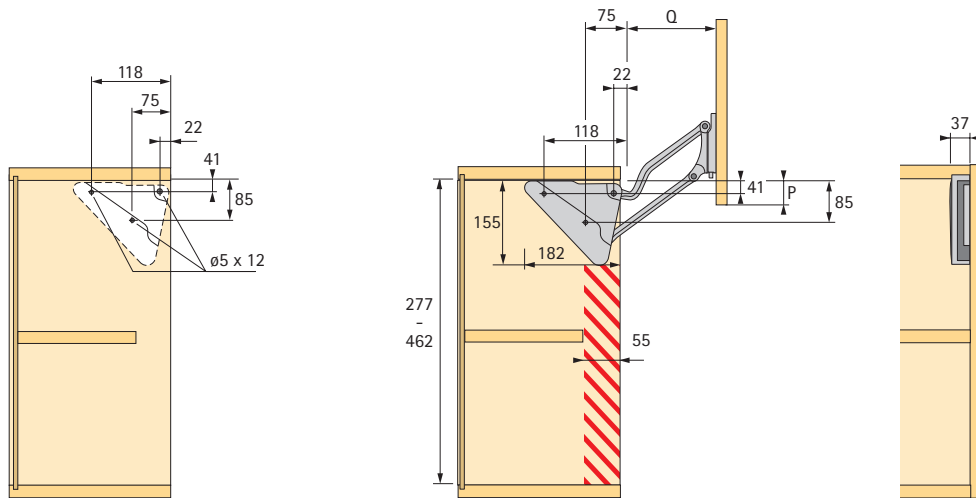

Internal cabinet height mm	Size P mm	Q mm	T mm
277 - 312	49	126	160
312 - 342	33	155	195
342 - 372	15	179	225
372 - 402	17	203	255
402 - 462	9	227	285

Front drilling pattern

for timber/timber-framed fronts and aluminium frame profiles 45 mm convex and 55 mm straight/convex

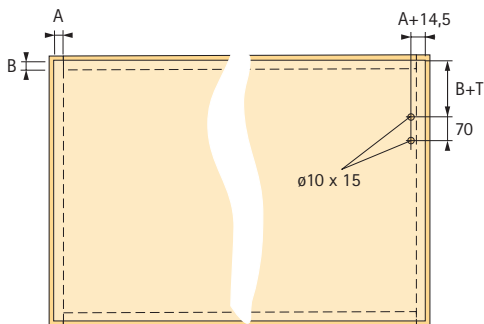

Front drilling pattern

for aluminium frame profile 19 mm

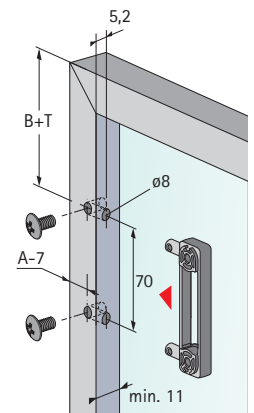
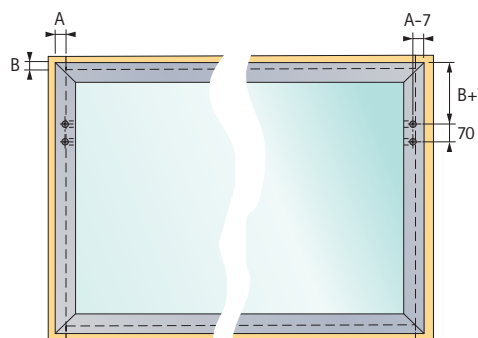



- For timber fronts and timber or aluminium framed fronts
- Max. flap/door weight 15,9 kg
- Adjustable opening and closing force
- Silent System integrated – dampened closing action
- The fitting can be adapted to different front weights by means of gas pressure springs which must be ordered separately, see pages 17 - 18
- Identical cabinet drilling pattern for Lift Advanced HF/HK/HL/HS
- Including fixing accessories
- Three-dimensional front adjustment :
Height ± 2 mm, side ± 2 mm, depth ± 2 mm
- Inside cabinet dimensions:
Height 380 - 750 mm
Depth min. 182 mm
Width min. 300 mm
- Housing and hinge mechanism of grey plastic/silver aluminium

Set contains:

- 1 flap fitting right/left
- 2 front adapters
- Fixing accessories



Internal cabinet height mm	Order no.	PU
380 - 750	9 079 617	1 set

**Shortenable cross member
for Lift-up flap fitting Lift Advanced HS**



For cabinet width mm	Order no.	PU
600	9 079 653	1 set
1200	9 079 658	1 set
1800	9 079 664	1 set



Adapter for aluminium frame profile

- For connecting the high-swing fitting Lift Advanced HS to aluminium frame profiles with a frame width of 19 mm

Order no.	PU
9 079 601	1 set

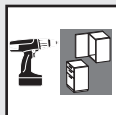

Pneumatic action

- For adapting the high-swing fitting Lift Advanced HS to different flap weights
- Simple installation and removal

Set contains:

2 springs (usable left and right)

Pneumatic action

for Lift-up flap fitting Lift Advanced HS
Internal cabinet height 380 - 500 mm

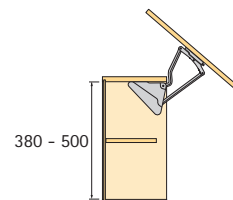

Flap weight in kg/Order no.

PU = 1 set

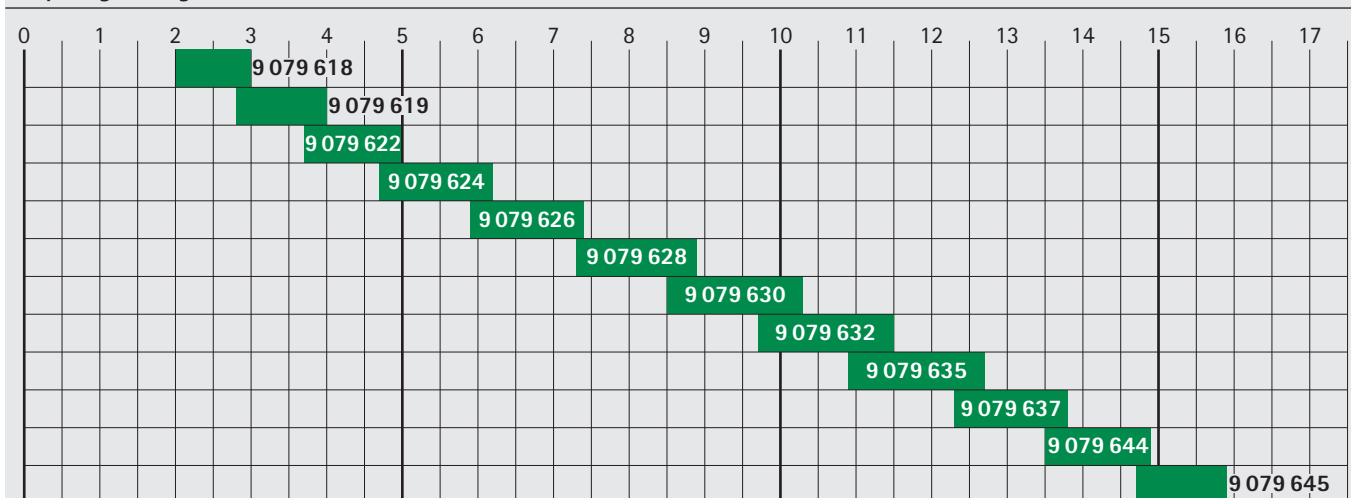

Pneumatic action

for Lift-up flap fitting Lift Advanced HS
Internal cabinet height 500 - 580 mm

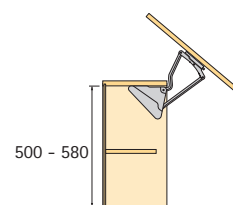

Flap weight in kg/Order no.

PU = 1 set

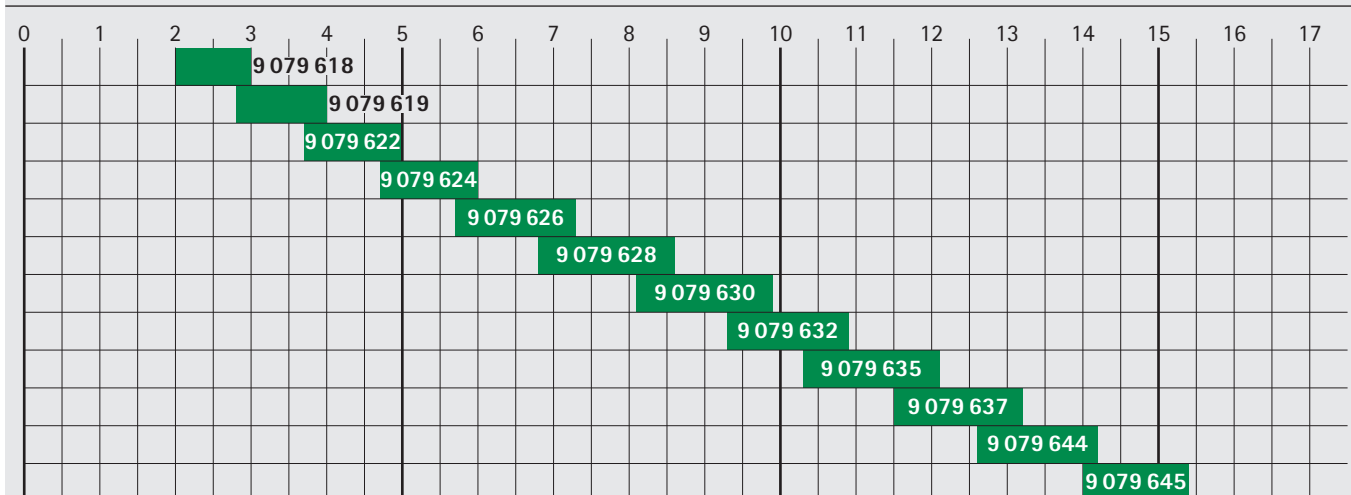

Lift-up flap fitting Lift Advanced HS

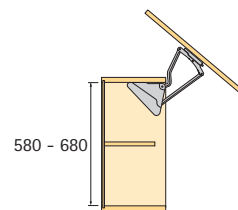

Pneumatic action

for Lift-up flap fitting Lift Advanced HS
Internal cabinet height 580 - 680 mm

Flap weight in kg/Order no.																	PU = 1 set
0	1	2	3	4	5	6	7	8	9	10	11	12	13	14	15	16	17
		9 079 618															
		9 079 619															
			9 079 622														
				9 079 624													
					9 079 626												
						9 079 628											
							9 079 630										
								9 079 632									
									9 079 635								
										9 079 637							
											9 079 644						
												9 079 645					

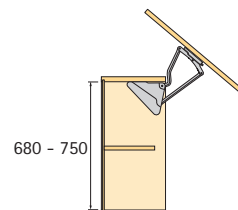

Pneumatic action

for Lift-up flap fitting Lift Advanced HS
Internal cabinet height 680 - 750 mm

Flap weight in kg/Order no.																	PU = 1 set
0	1	2	3	4	5	6	7	8	9	10	11	12	13	14	15	16	17
		9 079 619															
			9 079 622														
				9 079 624													
					9 079 626												
						9 079 628											
							9 079 630										
								9 079 632									
									9 079 635								
										9 079 637							
											9 079 644						
												9 079 645					

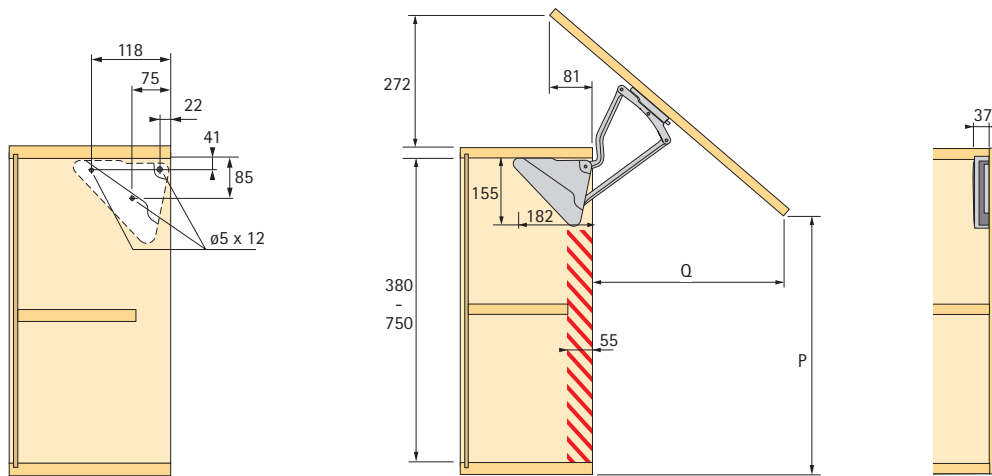

Internal cabinet height mm	Size P mm	Q mm
380 - 500	435	260
500 - 580	476	334
580 - 680	498	381
680 - 750	545	446

Front drilling pattern

for timber/timber-framed fronts and aluminium frame profiles 45 mm convex and 55 mm straight/convex

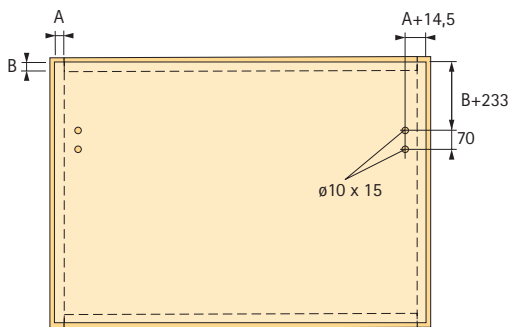

Front drilling pattern

for aluminium frame profile 19 mm

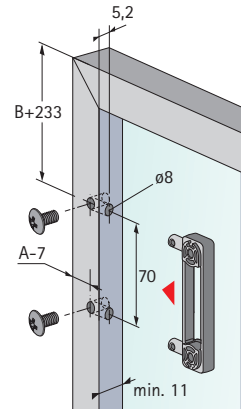
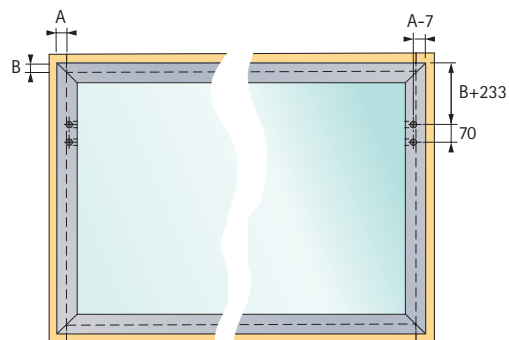

**Hettich Australia**

1 Herbert Place
Smithfield 2164, Sydney

Phone: (02) 96 16 77 00
Free Phone: 1800 68 77 89
Fax: (02) 96 16 77 78
Free Fax: 1800 15 01 29
e-mail: info@hettich.com.au

www.hettich.com.au

Hettich New Zealand

18 Barmac Place
East Tamaki, Auckland

Phone: (64) 92 74 40 36
Free Phone: 0800 4 38 84 24
Fax: (64) 92 74 81 77
Free Fax: 0800 73 78 47
e-mail: sales@hettich.co.nz

www.hettich.co.nz